

Monday 13 June 2022 – Morning

GCSE (9–1) Mathematics

J560/06 Paper 6 (Higher Tier)

Time allowed: 1 hour 30 minutes

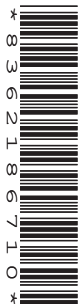

You must have:

- the Formulae Sheet for Higher Tier (inside this document)

You can use:

- a scientific or graphical calculator
- geometrical instruments
- tracing paper



Please write clearly in black ink. **Do not write in the barcodes.**

Centre number

--	--	--	--	--

Candidate number

--	--	--	--

First name(s)

Last name

INSTRUCTIONS

- Use black ink. You can use an HB pencil, but only for graphs and diagrams.
- Write your answer to each question in the space provided. If you need extra space, use the lined pages at the end of this booklet. The question numbers must be clearly shown.
- Answer **all** the questions.
- Where appropriate, your answers should be supported with working. Marks might be given for using a correct method even if your answer is wrong.
- Use the π button on your calculator or take π to be 3.142 unless the question says something different.

INFORMATION

- The total mark for this paper is **100**.
- The marks for each question are shown in brackets [].
- This document has **20** pages.

ADVICE

- Read each question carefully before you start your answer.

2

Answer **all** the questions.

- 1 A student rolls two fair four-sided dice each numbered 1, 2, 3 and 4. They add the two scores together.

(a) Complete the sample space diagram to show the possible outcomes from the dice.

		Second dice			
		Total	1	2	3
First dice	1	2			
	2				
	3				
	4				8

[2]

(b) Find the probability that the student gets an even total.

(b) [1]

(c) Find the probability that the student gets the same score on each dice.

(c) [1]

- 2 The circumference of a circle is 23 cm.

Show that the area of the circle is 42.1 cm^2 , correct to 3 significant figures.

[4]

3

- 3 Light from the Sun travels 1 kilometre in 3.3×10^{-6} seconds.
The distance from the Sun to the Earth is 1.5×10^8 kilometres.

How long does it take light to travel from the Sun to the Earth?
Give your answer in minutes and seconds.

..... minutes seconds [4]

- 4 You are given that

$$\frac{10a^k \times a^8}{ma^5} = \frac{2a^7}{5}$$

where k and m are integers.

Find the value of k and the value of m .

$k =$ and $m =$ [4]

5 In each row of the table there are two triangles.

State whether the two triangles are congruent or not.

If they are congruent state a reason from SSS, SAS, ASA or RHS.

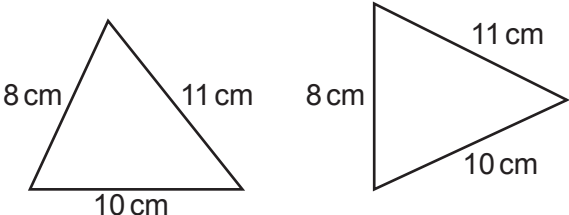
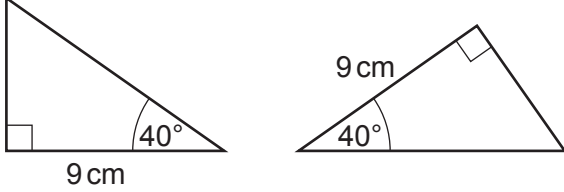
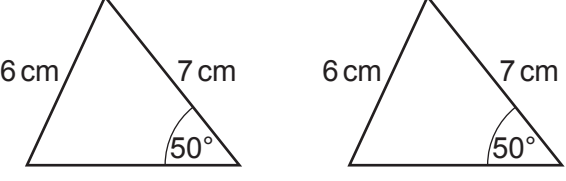
Triangles	Congruent (yes/no)	Reason (SSS/SAS/ASA/RHS)
<p style="text-align: center;">Not to scale</p> 		
<p style="text-align: center;">Not to scale</p> 		
<p style="text-align: center;">Not to scale</p> 		

[3]

- 6 The mass of a stone is 680 g.
The density of the stone is 1.6 g/cm^3 .

(a) Work out the volume of the stone.

(a) cm^3 [2]

(b) Write 1.6 g/cm^3 in kg/m^3 .

(b) kg/m^3 [1]

- 7 (a) Multiply out and simplify.

$$(x - 4)(x + 5)$$

(a) [2]

(b) Factorise.

$$x^2 - 25$$

(b) [1]

- 8 1600 fish are released into a new lake which has no fish.
The number of fish is expected to increase by 5% each year.

- (a) The table shows the expected number of fish in the lake at the end of 1 year and at the end of 2 years.

Complete the table.

Round your answers to the nearest integer.

Years after release	0	1	2	3	4
Expected number of fish	1600	1680	1764		

[3]

- (b) Use the table to draw a suitable graph to show the expected number of fish in the lake.

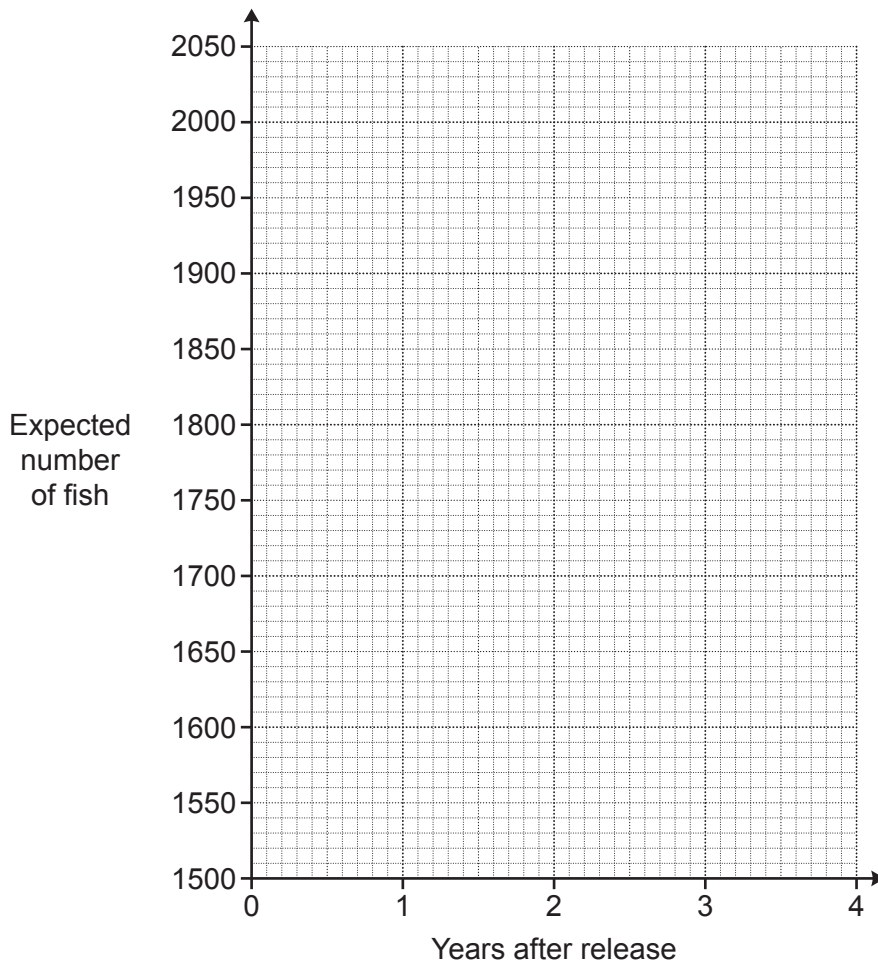

[3]

(c) A maximum of 2000 fish can live in the lake.

What effect would you expect this to have on the shape of your graph after 4 years?

.....

.....

..... [2]

- 9 A garage is trying to sell a car.
 The price of the car is normally £18 000.
 In a sale, the price of the car is reduced by 30%.
 As a special offer, the sale price is then reduced by $r\%$.
 The special offer price is £9450.

Find the value of r .
 You must show your working.

$r =$ [5]

- 10 The diagram shows a triangular prism and a cube.
The ends of the prism are right-angled triangles with base 16 cm and height 12 cm.
The prism is 18 cm long.

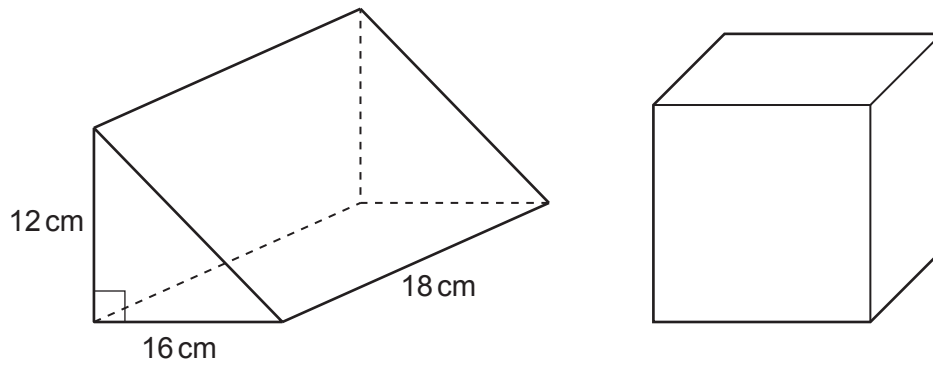

The volume of the prism is equal to the volume of the cube.

Find the **surface area of the cube**.
You must show your working.

..... cm² [6]

11 Amir, Beth and Charlie work in a cafe.

Customers give spare change as tips.

At the end of each week, Amir, Beth and Charlie share the total amount of tips between them in the ratio matching the number of hours they worked that week.

This week:

- Amir's share of the tips was £25.40.
- Beth worked twice as many hours as Amir.
- Charlie worked 5 more hours than Amir.
- The total hours worked by Amir, Beth and Charlie was 85 hours.

Calculate the total amount of tips received this week.

You must show your working.

£ [6]

- 12 A student has a spinner with sectors numbered 1, 2, 3 and 4.

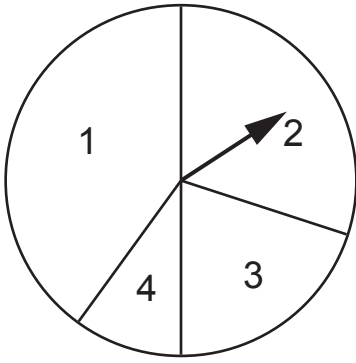

The table shows the probability of each score.

Score	1	2	3	4
Probability	0.4	0.3	0.2	0.1

The student spins the spinner twice.

Calculate the probability that the student gets the same score on each spin.

..... [4]

- 13 A car registration plate has two letters, a number from 10–99 and three letters.
For example:

AB56 CDE

The letters I and O are not used, leaving 24 possible letters.

Show that there are approximately 720 million possible car registration plates of this form. [4]

- 14 Sketch the graph of $y = \cos x - 1$ for $0^\circ \leq x \leq 720^\circ$.

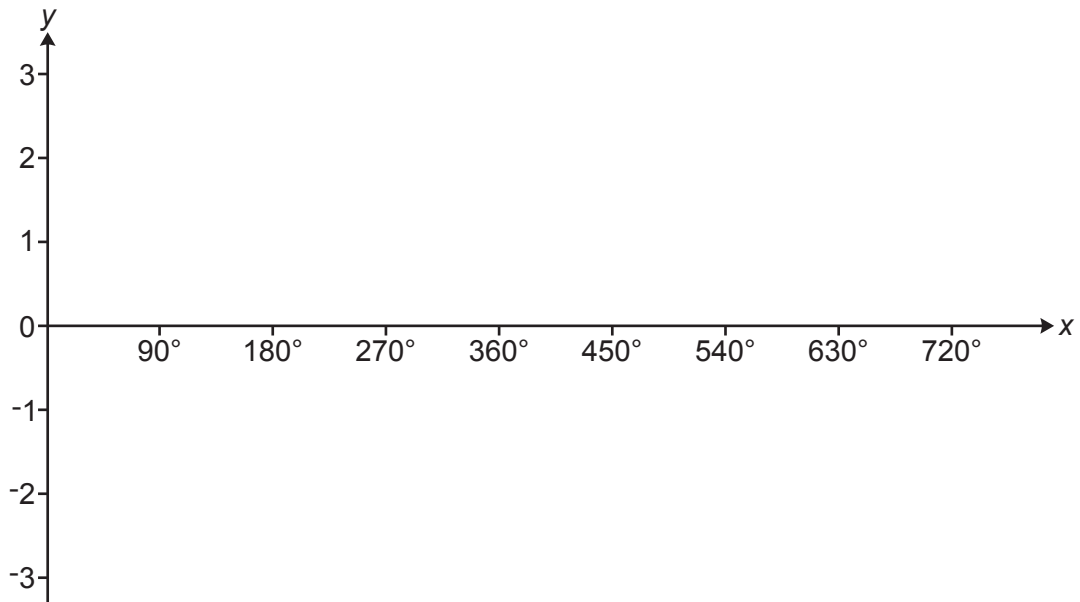

[3]

- 15 80 cyclists take part in a race.
A summary of their times is shown in the table.

Time (t minutes)	Frequency
$20 < t \leq 25$	5
$25 < t \leq 30$	15
$30 < t \leq 35$	24
$35 < t \leq 40$	25
$40 < t \leq 45$	7
$45 < t \leq 50$	4

- (a) Complete the cumulative frequency table.

Time (t minutes)	Cumulative frequency
$t \leq 25$	5
$t \leq 30$	
$t \leq 35$	
$t \leq 40$	
$t \leq 45$	
$t \leq 50$	

[2]

(b) Draw the cumulative frequency graph to show the information.

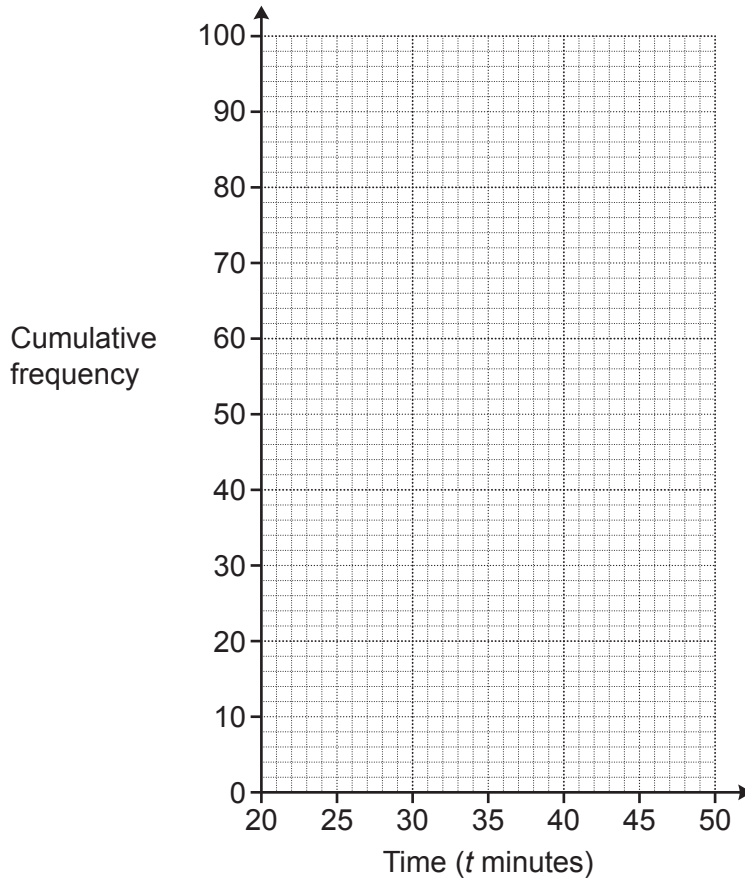

[3]

(c) Reece makes two comments about the times taken to complete the race.

For each comment, decide if Reece is right or wrong and give a reason for your answer.

(i) $\frac{3}{4}$ of the 80 cyclists took more than 30 minutes to complete the race.

Reece is because

.....

..... [2]

(ii) The longest time that any of the 80 cyclists took to complete the race must have been 50 minutes.

Reece is because

..... [1]

16 Frankie sketches this quadratic graph.

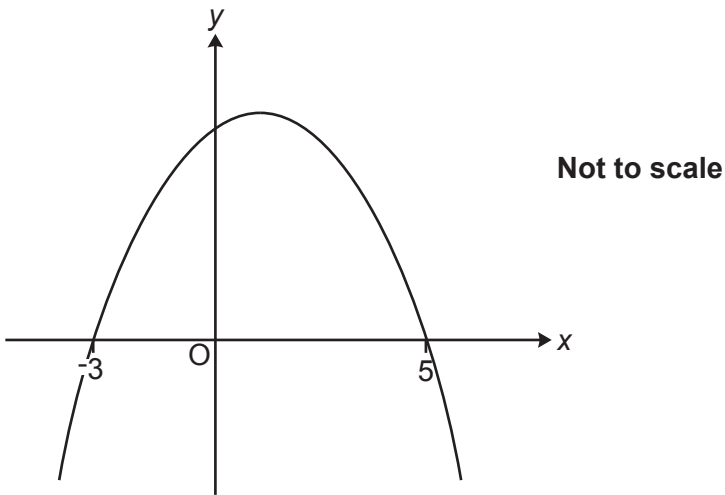

Frankie says

The y -intercept is 15.

(a) Show that what Frankie says could be correct.

[3]

(b) Explain why what Frankie says may **not** be correct.

.....

.....

.....

.....

[2]

17 Blake is asked to write 15 552 000 000 as a product of prime factors in index form.
Blake writes

$$15552000000 = 2^7 \times 5^6 \times 6^5.$$

(a) Explain Blake's mistake.

.....
.....
..... [1]

(b) Write 15 552 000 000 as a product of prime factors in index form.

(b) [2]

(c) You are given that $140000 = 2^5 \times 5^4 \times 7$.

Find the highest common factor (HCF) of 15 552 000 000 and 140 000.

(c) [2]

18 The graph of $y = 2x + 1$ is drawn on this one centimetre grid.

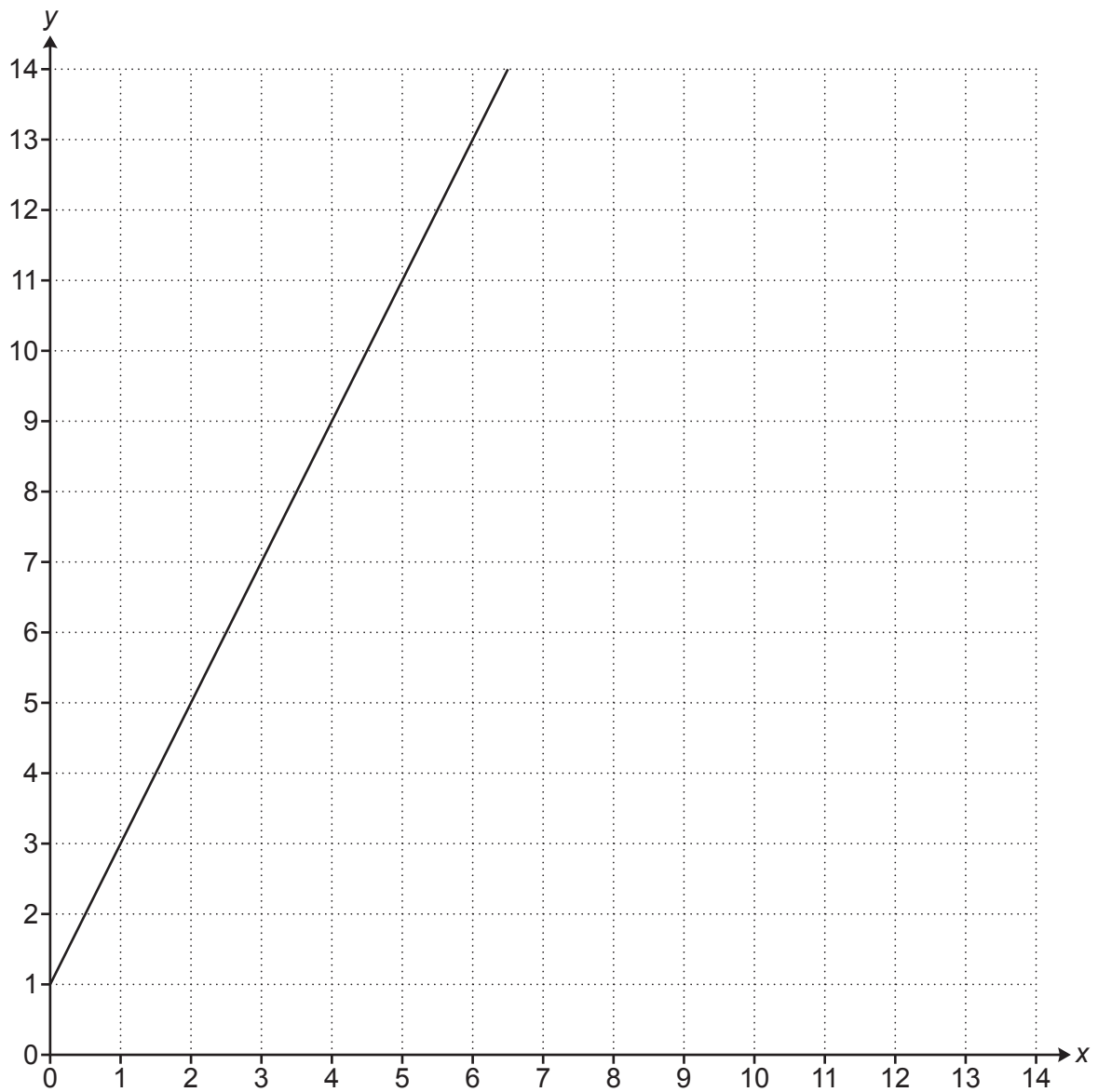

The region **R** satisfies these inequalities.

$$y \leq 2x + 1$$

$$y \geq 5$$

$$x + y \leq 13$$

Show that the area of region **R** is 12 cm^2 .

[6]

19 (a) Write $x^2 - 8x + 9$ in the form $(x - a)^2 - b$.

(a) [3]

(b) Use your answer from part (a) to solve.

$$x^2 - 8x + 9 = 0$$

Give your answers in exact form.
You must show your working.

(b) $x = \dots\dots\dots$ or $x = \dots\dots\dots$ [2]

20 Two pyramids, A and B, are mathematically similar.

Pyramid A has surface area 12 cm^2 and volume 8 cm^3 .
Pyramid B has surface area 75 cm^2 .

Work out the volume of pyramid B.
You must show your working.

..... cm^3 [4]

- 21 The diagram shows triangle ABC.
X lies on BC such that angle $AXC = 90^\circ$.

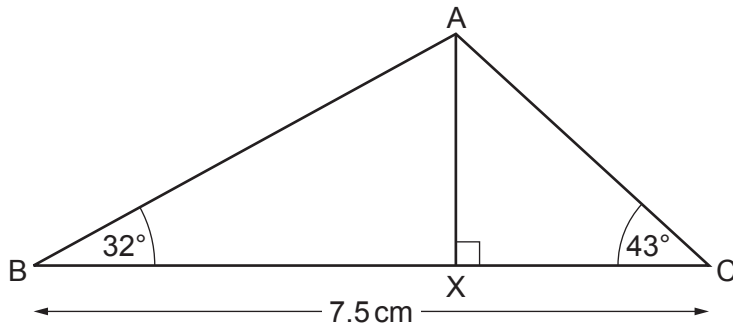

Not to scale

$BC = 7.5$ cm, angle $ABC = 32^\circ$ and angle $ACB = 43^\circ$.

Work out length AX.
You must show your working.

..... cm [6]

END OF QUESTION PAPER

ADDITIONAL ANSWER SPACE

If additional space is required, you should use the following lined page(s). The question number(s) must be clearly shown in the margin(s).

A large rectangular area with a vertical solid line on the left side and horizontal dotted lines across the rest of the page, providing space for writing answers.



Copyright Information

OCR is committed to seeking permission to reproduce all third-party content that it uses in its assessment materials. OCR has attempted to identify and contact all copyright holders whose work is used in this paper. To avoid the issue of disclosure of answer-related information to candidates, all copyright acknowledgements are reproduced in the OCR Copyright Acknowledgements Booklet. This is produced for each series of examinations and is freely available to download from our public website (www.ocr.org.uk) after the live examination series. If OCR has unwittingly failed to correctly acknowledge or clear any third-party content in this assessment material, OCR will be happy to correct its mistake at the earliest possible opportunity.

For queries or further information please contact The OCR Copyright Team, The Triangle Building, Shaftesbury Road, Cambridge CB2 8EA.

OCR is part of Cambridge University Press & Assessment, which is itself a department of the University of Cambridge.